

**Druck- und Zugkraftsensor für Materialprüfmaschinen**

**K- 11**

**Compression and Tension Force Sensor for Material Testing Machines**

- Messbereich 0,5 ... 2000 kN
- Für Druck- und Zugkraft
- Hohe Genauigkeit
- Hohe Langzeitstabilität
- Für Materialprüfmaschinen
- Rostbeständiger Edelstahl
- Schutzart IP60
- Measuring range 0.5 ... 2000 kN
- For compression force and tension force
- High accuracy
- Long-term stability
- For material testing machines
- Stainless steel
- Level of protection IP60

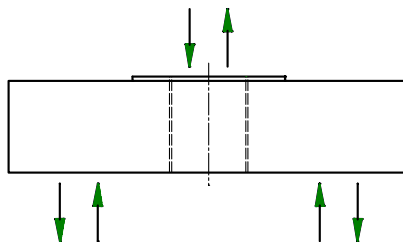

<b>Anschlussbelegung - Connection</b>	
Versorgung (-) - Supply (-)	Pin 1
Versorgung (+) - Supply (+)	Pin 2
Schirm - Shield	Pin 3
Signal (+) - Signal (+)	Pin 4
Signal (-) - Signal (-)	Pin 5
Kontrolle (Option) - Calibration control (option)	Pin 6

**Mechanische Abmessungen - Dimensions**

**K-11**

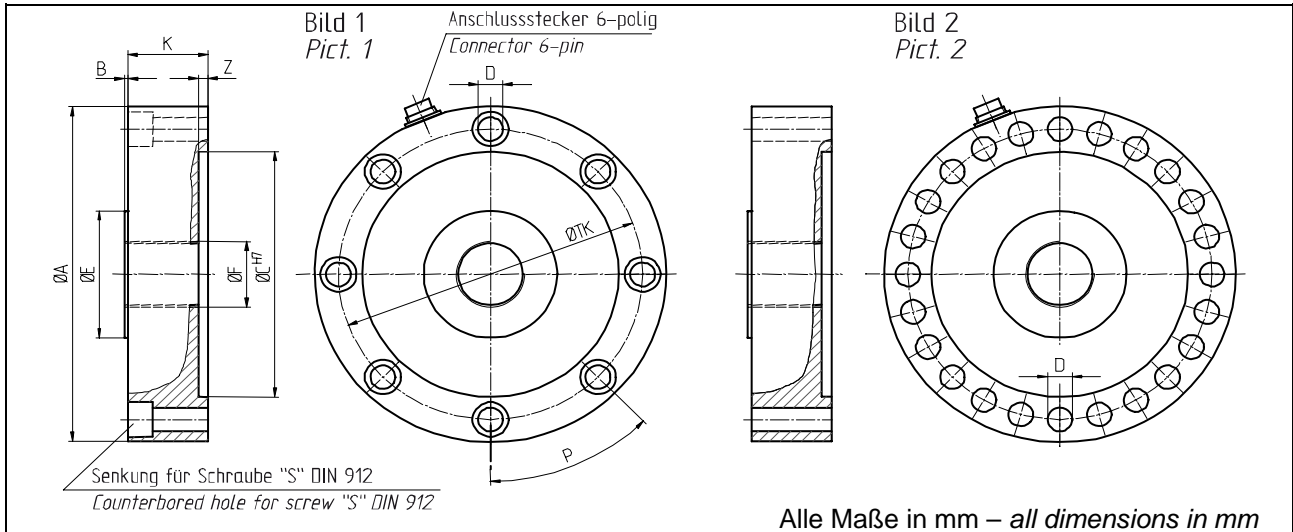

Alle Maße in mm – all dimensions in mm

Messbereich Meas. range [kN]	Ø A	B	Ø C	Ø D	Ø E	Ø F	K	Ø TK	P	S für for	Z	Bild Pict.	Schrauben- anzugsmoment - Tightening torque [N.m]
0,5/1/2/5/10	90	2	60	6,6	25	M12	32	75	4 x 90°	M6	2	1	0,8
20 / 50	150	2	105	11	55	M24 x 2	38	130	8 x 45°	M10	2	1	40
100 / 200	185	2	135	13	70	M36 x 3	42	160	8 x 45°	M12	3	1	70
500	240	2	160	17	90	M45 x 3	60	200	12 x 30°	M16	3	1	160
1000	295	5	200	21	130	M80 x 4	95	250	12 x 30°	M20	4	2	610
2000	390	3	270	26	190	M120 x 4	117	330	24 x 15°	M24	4	2	1050

**TECHNISCHE DATEN - SPECIFICATIONS**

Typ – Type	K-11			
Genauigkeitsklasse Druckkraft oder Zugkraft - Accuracy class compression force or tension force	S%	0,05	0,2	0,5
Genauigkeitsklasse Druckkraft und Zugkraft - Accuracy class compression force and tension force	S%	0,1	0,4	1,0
Gebrauchslast - Service load	S%	130		
Grenzlast - Limit load	S%	150		
Bruchlast - Ultimate load	S%	>300		
Max. dynam. Belastung - Max. dynamic load (DIN 50 100)	S%	80		
Nennmessweg - Position feedback	mm	<0,12		
Brückenwiderstand - Bridge resistance	Ω	350		
Isolationswiderstand - Insulation resistance	Ω	>2*10 <sup>9</sup>		
Speisespannung - Supply voltage	V	2 ... 12		
Max. Speisespannung - Max. supply voltage	V	15		
Nennkennwert (S) - Sensitivity (S)	mV/V	2,00		
Kennwerttoleranz - Tolerance of sensitivity	S%	<±0,1		
Temp.koeff. des Kennwertes - Temp. coeff. of sensitivity	S%/10K	0,05	0,07	0,12
Temp.koeff. des Nullsignals - Temp. coeff. of zero signal	S%/10K	0,03	0,05	0,10
Referenztemperatur - Reference temperature	°C	+23		
Nenntemperaturbereich - Nominal temperature range	°C	0 ... +60		
Gebrauchstemperaturbereich - Service temperature range	°C	-10 ... +70		
Lagerungstemperaturbereich - Storage temperature range	°C	-30 ... +95		
Veränderlichkeit - Repeatability	S%	0,03	0,08	0,15
Rel. Kriechen - Rel. Creep	S%/30min	<±0,03	<±0,08	<±0,15
Werkstoff - Material	Rostbeständiger Edelstahl - Stainless steel			
Schutzart - Level of protection (DIN EN 60529)	IP60			
Elektrischer Anschluss - Electrical connection	6-polig Serie 723 - 6-pin series 723			

**Optionen/ Zubehör - Options/ Accessories**

Kontrolle - Calibration control	S%	100
6-Leitertechnik - 6-wire connection		
Gelenköse Typ EM Datenblatt Nr. 080374 - Rod end type EM data sheet no. 080374		
Druckstück Typ E2 Datenblatt Nr. 080374 - Thrust piece type E2 data sheet no. 080374		
Adapter Typ E3 Datenblatt Nr. 080374 - Adapter type E3 data sheet no. 080374		

Bitte den gewünschten Messbereich und die Genauigkeitsklasse angeben! Please specify the required meas. range and accuracy class!